

myone



SLIM

**compact
sliding doors**

LUCE S

The Luce S automatic sliding door operators are perfect for automating pedestrian access points in areas with specific aesthetic or architectural requirements. With its ultra-compact supporting profile and cover, only 10 cm high, the operator works perfectly in any architectural context reducing the aesthetic impact to a minimum. Also available in single-leaf (up to 110 kg) or double-leaf (up to 70+70 kg) versions.

LUCE S



download LUCE S instructions and certificates

www.myoneautomation.com

Operator for sliding doors with carriages designed to ensure that the doors are very stable and easy to adjust, both in height and depth. Reduced size system (only 10 cm high). The operator has a control unit with LED alphanumeric display, full-range switching power supply (100-240 V 50/60 Hz) and battery charger. The presence of a USB connector makes it quick and easy to update the firmware as well as to copy parameters and operating logics to a new system instantly. Continuous operation guaranteed.

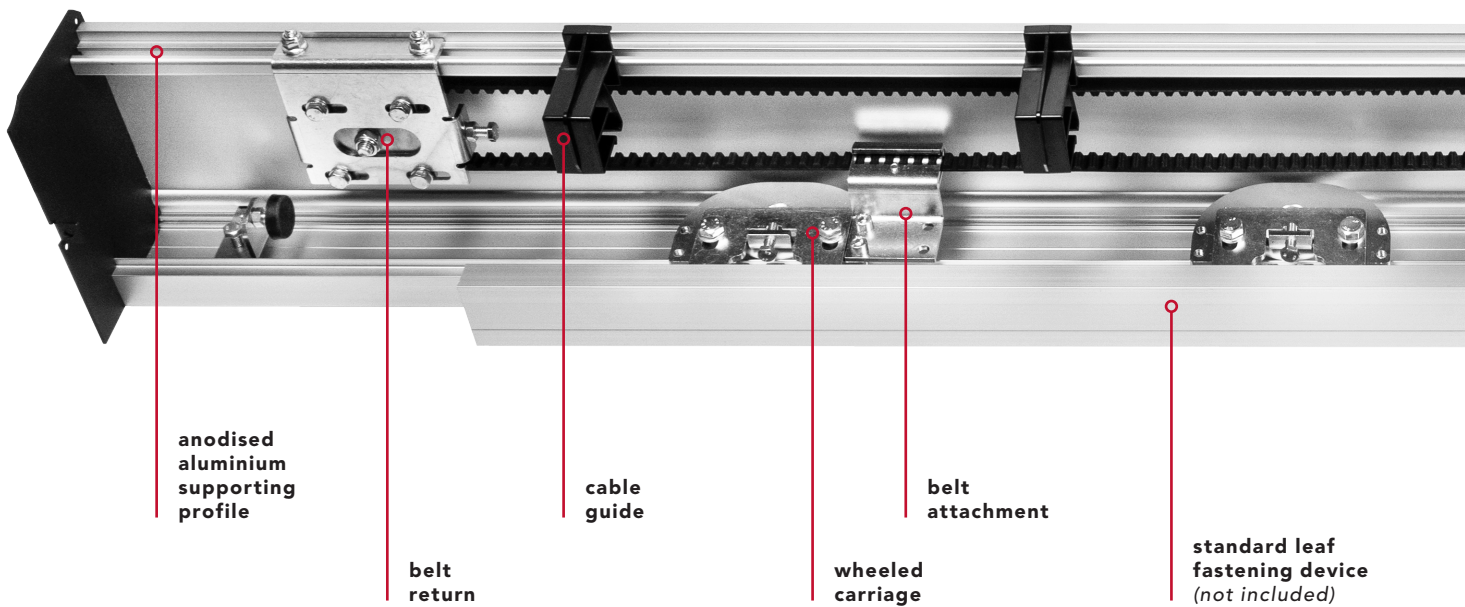

anodised aluminium supporting profile

belt return

cable guide

wheeled carriage

belt attachment

standard leaf fastening device (not included)

technical data

power supply	full range 100÷240 Vac 50/60 Hz
power consumption	70 W
power consumption in stand-by	3 W
accessories power supply	24 Vdc = / 1 A max
maximum speed 1 door	0.8 m/s
maximum speed 2 doors	1.6 m/s
maximum load 1 door	110 kg
maximum load 2 doors	70 + 70 kg
type and frequency of use	continuous operation = 100%
operating temperature	-15°C / +50°C
protection degree	IP20
data backup memory	USB flash drive



1 leaf
max. weight
110 kg



2 leaves
max. weight
70 + 70 kg

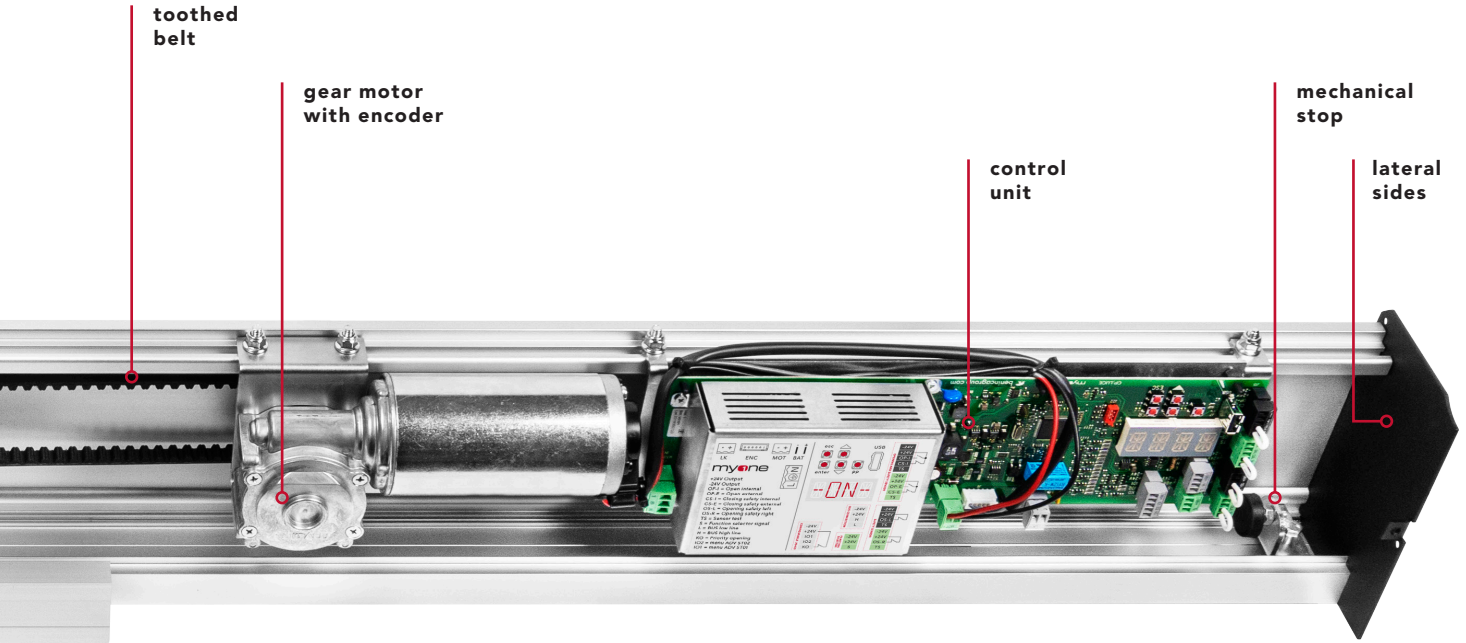

compact preassembled

*The values of the passage size (A) and of the leaf are indicative and include an overlap of around 50 mm.

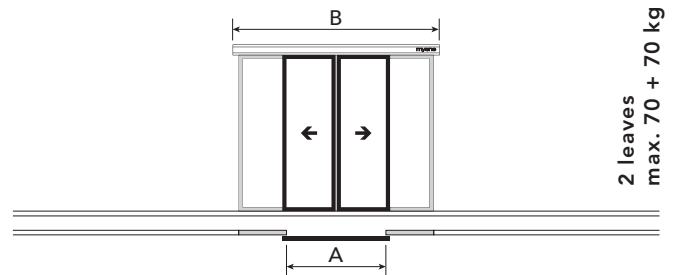
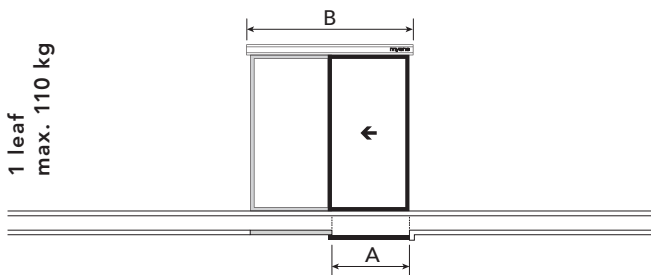

	A	B
LUCES1901S	900 mm	1900 mm
LUCES2101S	1000 mm	2100 mm
LUCES2501S	1200 mm	2500 mm
LUCES2901S	1400 mm	2900 mm
LUCES3301S	1600 mm	3300 mm
LUCES3701S	1800 mm	3700 mm
LUCES4201S	2000 mm	4200 mm
LUCES5001S	2450 mm	5000 mm
LUCES6501S	3100 mm	6500 mm

	A	B
LUCES1902S	900 mm	1900 mm
LUCES2102S	1000 mm	2100 mm
LUCES2502S	1200 mm	2500 mm
LUCES2902S	1400 mm	2900 mm
LUCES3302S	1600 mm	3300 mm
LUCES3702S	1800 mm	3700 mm
LUCES4202S	2000 mm	4200 mm
LUCES5002S	2450 mm	5000 mm
LUCES6502S	3100 mm	6500 mm

the preassembled operator is made up of:

control unit | gear motor with encoder | wheeled sliding carriages | anodised aluminium supporting profile and cover | belt return | mechanical stop | belt | cable guide | screw kit | lateral sides



MYONE Srl

Via Abbate Tommaso, 52
30020 Quarto D'Altino (VE) ITALY

T +39 0422 824384

info@myoneautomation.com
www.myoneautomation.com